

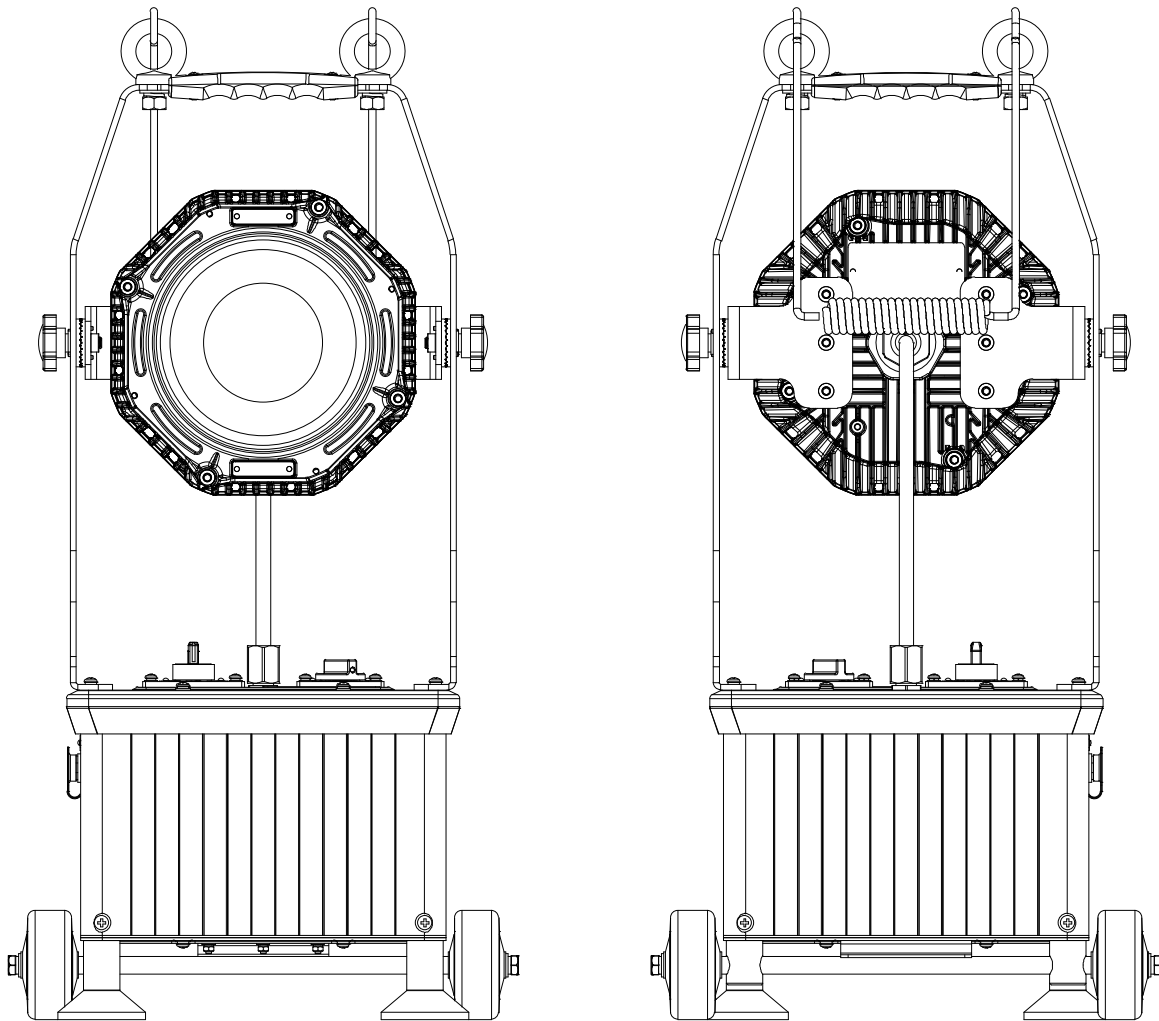

Operation & Maintenance Manual Saturn Series-NV1.0



Important information:

These instructions contain safety information, read and follow them carefully. KHJ will not accept any responsibility for injury, damage or loss which may occur due to incorrect installation, operation or maintenance

Product Important Information

Type Of Protection	Ex d e
Protection Standards	(IEC)EN 60079-0, (IEC)EN 60079-1, (IEC)EN 60079-7 EN 55015, EN 61547, EN 61000-3-2, EN 61000-3-3, EN 60598-1, EN 60598-2-5, EN 62031, EN 62493, IEC 62321-4, IEC 62321-5, IEC 62321-6, IEC 62321-7-1, IEC 62321-7-2, IEC 62321-8
Area Classification	Zone1 Areas to (IEC)EN 60079-10-1,
Installation	(IEC)EN 60079-14
Certificate	ATEX: ECM 17 ATEX-B TD45 IECEX: IECEX CQM 16.0005X
Equipment Coding	Ex d e IIC T5 Gb IP54
Temperature Class	-20 ≤ TA ≤ +55
ATEX Coding	 II 2 G
Ingress Protection	IP54 (IEC)EN 60529
CE Mark	The CE marking of this product applies to EU directives 2014/35/EU, 2014/30/EU, 2012/19/EU and 2014/34/EU respectively. The Equipment is declared to meet the provisions of the ATEX directive(2014/34/EU)by reason of the EU Type Examination and compliance with the Essential Health and Safety Requirements

01.Introduction-Saturn series LED light ATEX and IECEx

- This user manual covers the range of ATEX and IECEx Saturn series luminaire.
These luminaires are constructed with corrosion resistant epoxy coated copper free aluminum alloy body and high impact resistance tempered glass diffuser.
- Saturn series luminaire are available from 5-60W, providing ideal solutions for a wide range of harsh and hazardous applications.

02.Electrical Supplies

Size:695*350*218mm		
Power Watts(W)	60W	
Battery Charge Time	<7h	
Rated Capacity	Lead-acid batteries	
Charge Voltage(VAC)	100-277 VAC	
Battery Rated Capacity	12Ah	
Battery Back Up	Power Watts	Times
	15W	12h
	30W	8h
	60W	4h
Power Factor	≥0.6	

03.General

- These instructions should be read fully and carefully before attempting to install the luminaire.
For details of servicing operations, opening etc. see section 6.
- Copies of these instructions should be held in a safe place for future reference.
It is the responsibly of the installer to ensure that the apparatus selected is fit for it is intended purpose and that the installation, operation and maintenance of the apparatus complies with applicable regulations, standards or codes of practice.
Installation should be carried out in accordance with(IEC)EN60079-14 or with a local hazardous area code of practice, whichever is appropriate.
- Risk of electrostatic discharge:
 - a.Avoid mounting near fast moving streams of air

- Any specific installation instructions must be referred to The luminaire should be considered Class I to EN 60598 and effectively earthed.
Certification details on the nameplate must be verified against the application requirements before installation.
- The information in this leaflet is correct at the time of publication.
The company reserves the right to make specifications changes as required without notice.
The luminaire are shipped with the battery pack disconnected, connection must be made on the initial insulation.
- Refer to (IEC)EN60079-10-1 & (IEC)EN60079-14 for additional details of selection and installation.

3.1 Tools

- 4 mm and 5 mm flat blade screwdriver, large cross head screwdriver and inner hexagon counter wrench, suitable spanners for installing cable gland, pliers, knife, wire stripper and cutter.

3.2 Mounting

- Luminaire should be installed where access for maintenance is practical and in accordance with lighting design information. Refer to the note in 3. concerning electrostatic charge. See 6.1 installation diagram for installation mode and method.

04.Safety instruction

- Read this leaflet carefully before commencing to install the luminaire unit and retain it for future use.
Installation can only be carried out by suitably qualified personnel.
- Check the certification to ensure that the Zone, mains supply, ambient temperature present and "T" rating are suitable for the environment the unit is being installed in.
- Do Not Open When Energised, After De-Energising, Delay 10 Minutes Before Opening .
- Potential Electrostatic Charging Hazard-See Instructions .
- Do Not Open When An Explosive Gas Atmosphere Is Present.
- To ensure the safety of the equipment, ensure that the 'flame-path' on Zone 1 variants are free from any corrosion.
No repairs are possible to flameproof joints if in doubt please consult the manufacturer.
- External fasteners must have a yield strength of at least 450N/mm²
- On Zone 1 variants the LED assembly contains no user service able parts, the luminaire must not be operated without all the individual LED covers in position, the IP54 rating must be maintained.



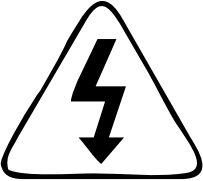

Isolate mains before removing cover



Install in a well ventilated area



Do not continually stare at lamp

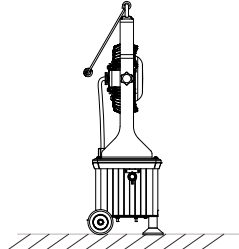

05.Charge display

- When the power adapter indicates the LED light "red", charging.
- When the power adapter indicates the LED light "green" charging is complete.

06. Installation method

Based on the use of the scene and actual requirements, we have designed the following installation methods for customers to choose from (including but not limited to):

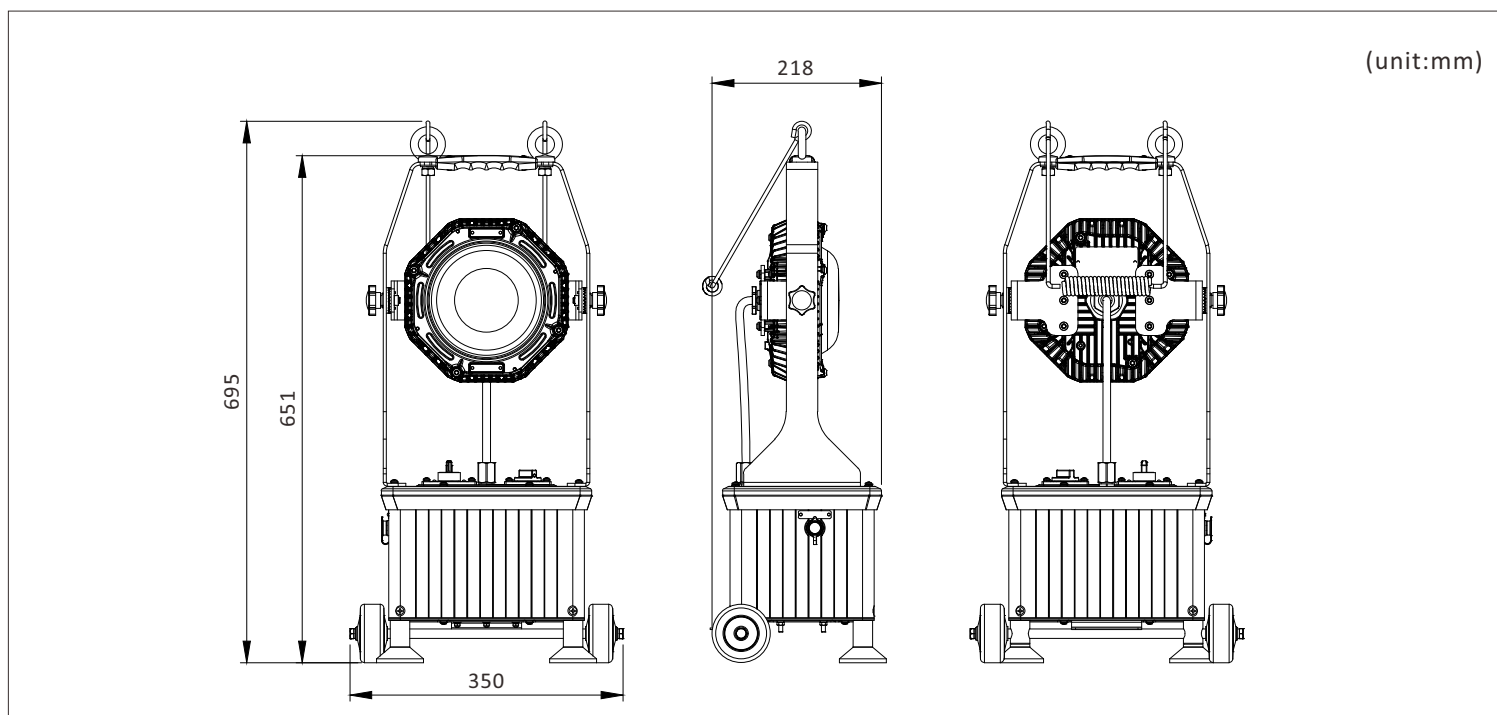

6.1 Installation decomposition

It is the responsibility of the installer to ensure that the apparatus selected is fit for its intended purpose and that the installation, operation and maintenance of the apparatus complies with applicable regulations, standards or codes of practice.

Installation should be carried out in accordance with (IEC)EN60079-14 or with local hazardous area code of practice, whichever is appropriate.

Please refer to the following installation drawing for different installation methods.

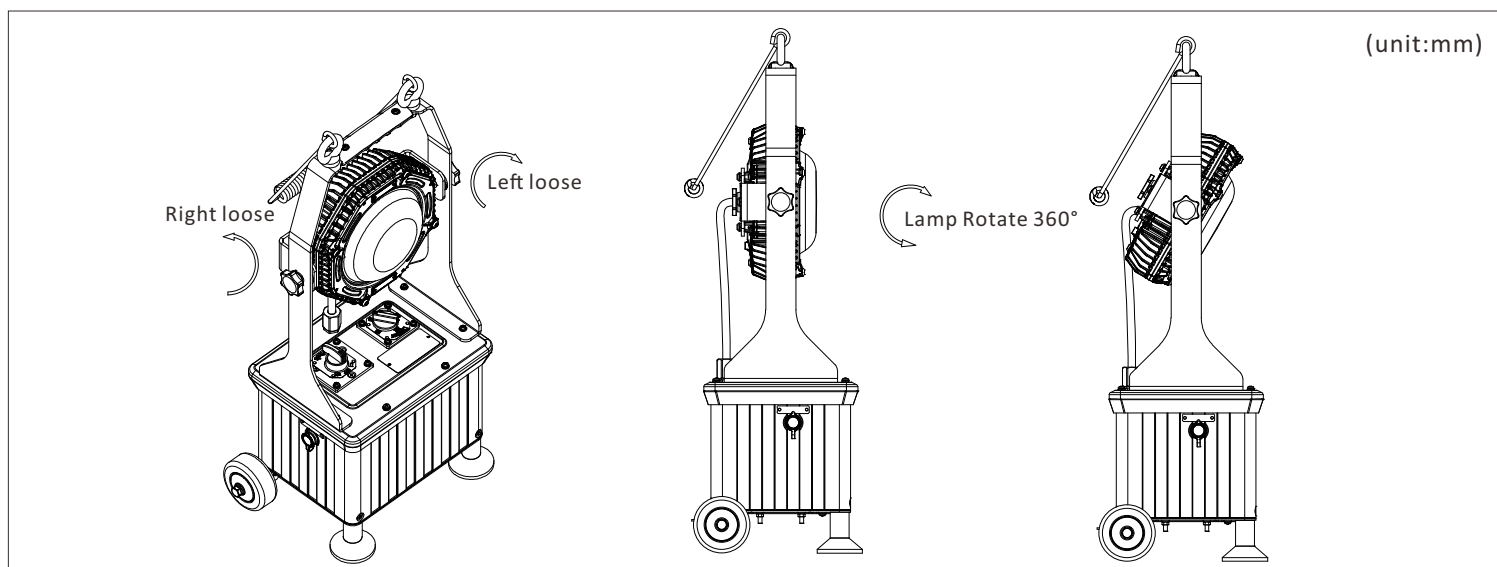

Note: the size of the structure is for reference only. We reserve the right to optimize and adjust some parts of the structure without notice.

07.Repairs Maintenance

Visual tests and checks should be carried out at intervals described by the appropriate regulations, (IEC)EN 60079-17, and should include the following (including but not limited to).

- Check for mechanical damage/corrosion.
- Check connections, fixings
- Check for undue accumulations of dust, dirt or moisture.
- Check for unauthorized modifications.

Periodic inspection of the enclosure seal should be checked out to ensure that the seal is sound.

If the luminaire has been subject to abnormal conditions, for example, severe mechanical impact or chemical spillage, it must be de-energised until it has been inspected by an authorized and competent person.

08.Cleaning of luminaire

- The complete luminaire (without disassemble) can be cleaned with neutral water solution.
After cleaning, rinse or wipe dry with clean water.
- It is forbidden to use any chemical or hydrocarbon solvent cleaner to clean the diffuser, otherwise serious damage may be caused.
- Please clean the luminaire regularly if it is used under dust environment.

09.Disposal of Material

General

Disposal of the luminaire as waste should be carried out in accordance with national regulations.

Any disposal must satisfy the requirements of the WEEE directive [2012/19/EU] and therefore must not be treated as commercial waste.

The unit is mainly made from incombustible materials.

The control gear contains plastic, resin and electronic components.

All electrical components may give off noxious fumes if incinerated.

9.1 Battery Disposal

Ni-Cd batteries are defined as 'controlled waste' under the hazardous waste regulations and the person disposing needs to observe a 'duty of care'.

They must be stored and transported safely and any necessary pollution control forms completed prior to transportation.

Take care to fully discharge batteries before transporting, or otherwise ensure that there can be no release of stored energy in transit.

For further details refer to our technical department.



To comply with the Waste Electrical and Electronic Equipment directive 2012/19/EU the apparatus cannot be classified as commercial waste and as such must be disposed of or recycled in such a manner as to reduce the environmental impact.

10.Transportation

Weatherproof measures should be taken during transportation.

It is strictly forbidden to load and unload violently, and it is strictly forbidden to drop and roll from high altitude, so as to prevent mechanical damage.

11.Storage

The luminaire should be stored in ventilated, non-dropping and non-liquid warehouse at the temperature of -20°C to +40°C and relative humidity ≤95%RH.

The surroundings should be kept from corrosive gases which may damage metal and insulation.

The battery should be fully charged and discharged at least once every 6 months.



Rev: 01 / 19.03.2024

Contact

SHENZHEN KHJ SEMICONDUCTOR LIGHTING CO., LTD.

Web: www.khjled.com

Address: 4-5 Floor, Building 1, Chuangxin industrial park, Xintian community, Guanlan, Longhua new district, Shenzhen, China.

Tel: +86-755-82949977
E-mail: khjledsales@khj.cn

Fax: +86-755-82949800
Web: www.khjled.com