



SHENZHEN KHJ SEMICONDUCTOR LIGHTING CO., LTD.

Operation & Maintenance Manual

KVictoriaHarbour Series -V1



Ex Mark

II 2 G Ex db op is IIC T5 or T6 Gb
II 2 D Ex tb op is IIC T95°C or T80°C Db IP66

Add : 4-5 Floor, Building 1, Chuangxin industrial park, Xintian community, Guanlan, Longhua new district, Shenzhen, China.
Tel: +86-755-82949977
Fax: +86-755-82949800
Web: www.khjled.com

1. Brief Introduction

1.1. Copper free aluminium enclosure, 3 optional terminal blocks for easy connection, to meet different termination requirements.

2. Application

2.1. Designed to be used in classified hazardous areas, to connect and disconnect operation of lighting and light power loads.
2.2. Ambient temperature from -45°C to +55°C.

3. Executive standard

- 3.1 IEC 60079-0 Electrical apparatus for explosive gas atmospheres--Part 1: General requirements
- 3.2 IEC 60079-1 Explosive atmospheres--Part 2: Equipment protection by flame proof enclosures "d"
- 3.3 IEC 61241-0 Electrical apparatus for use in the presence of combustible dust--Part 1: General requirements
- 3.4 IEC 60947-5-1 Low-voltage switchgear and controlgear. Part 5-1: Control circuit devices and switching elements. Electromechanical control circuit devices
- 3.5 EN 60079-0 Electrical apparatus for explosive gas atmospheres--Part 1: General requirements
- 3.6 EN 60079-1 Explosive atmospheres--Part 2: Equipment protection by flameproof enclosures "d"
- 3.7 EN 61241-0 Electrical apparatus for use in the presence of combustible dust--Part 1: General requirements
- 3.8 EN 60947-5-1 Low-voltage switchgear and controlgear. Part 5-1: Control circuit devices and switching elements. Electromechanical control circuit devices

4. Product certification

4.1. ATEX, RoHS and CE.

5. Caution

- 5.1. This product should be installed and maintained by qualified electrician only.
- 5.2. Do not operate in ambient temperatures above those indicated on the nameplate.
- 5.3. Repair of the flameproof joint must be made in compliance with the structural specifications provided by the manufacturer.
- 5.4. The assembly should be equipped with certified cable glands with a compatible mode of protection for the intended use. The unused holes should be closed by certified plugs.
- 5.5. Make sure the electrical power is OFF before making installation and maintenance.
- 5.6. Do not open when energized.
- 5.7. After de-energizing, delay 10 minutes before opening.
- 5.8. Typically full discharging and charging once every half a year.

6. Installation method

6.1. This series products Installation methods Conduit Installation.

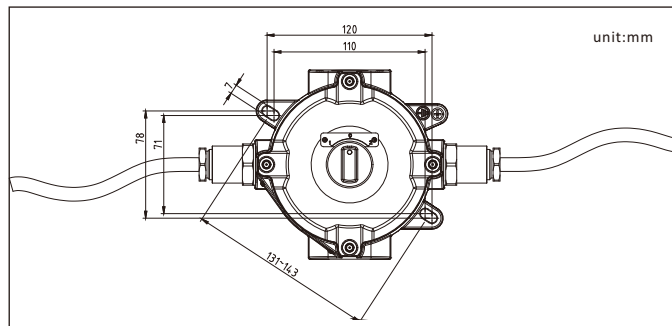

6.2. Installation method:

- a. Fix the installation location according to the mounting holes. (Picture 6.2)
- b. Fix to the installation surface with M6X40 expansion bolts. (Picture 6.2)

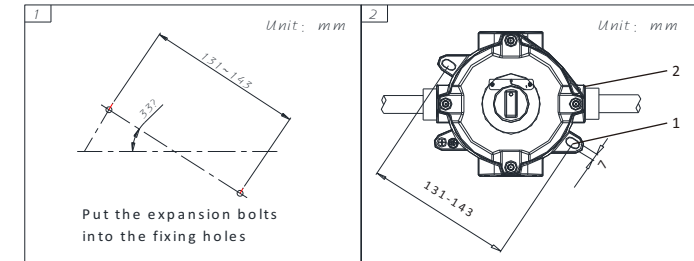

1. Switch

2. (M6×40) Expansion bolts(M6X40) (Picture6.2)

6.3. Switch wiring:

Use 3 core cable(cable size $\Phi 3 \sim \Phi 18$) and suitable cable gland:According to the below wiring process:

- 6.3.1. wire stripping. (Picture 6.3)
- 6.3.2. Open the top cover with 4mm hexagon wrench. (Picture 6.3)
- 6.3.3. Put the cable through the cable gland to the box. (Picture 6.3)
- 6.3.4. Connect the L wire and N wire with switch, GND wire with grounding block.
- 6.3.5. Fasten the top cover and cable gland after cable connection. (Picture 6.3)

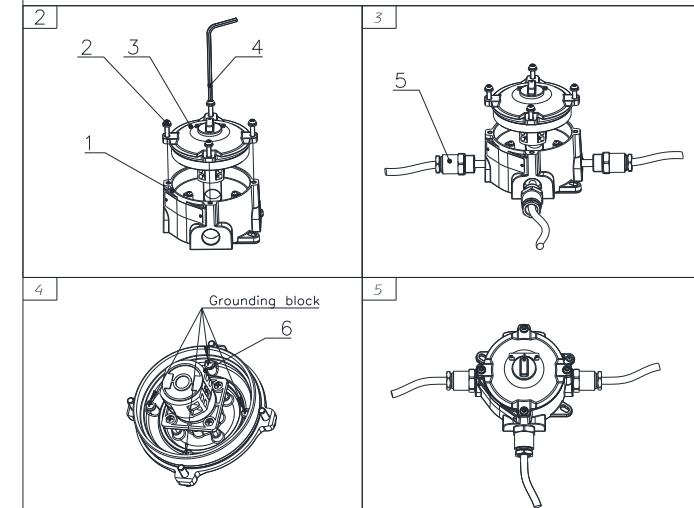
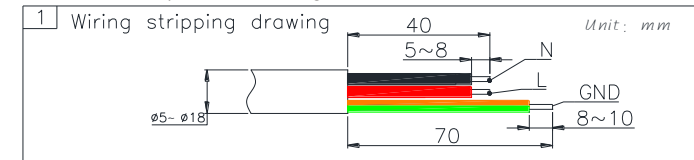

1. enclosure 2. Allen screw 3. Top cover
4. 4mm Hexagon wrench 5. cable gland 6. Switch
(Picture6.3)

6.4. Switch connection methods and operations:

6.4.1.0-1 type:

- a. Do wiring and operation according to the switch working circuit. (Picture 6.4)
- b. 0: Switch off 1: Switch on

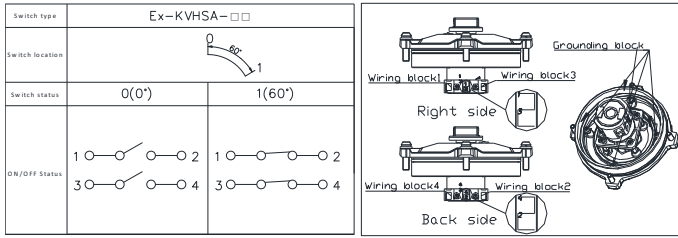

(Picture6.4)

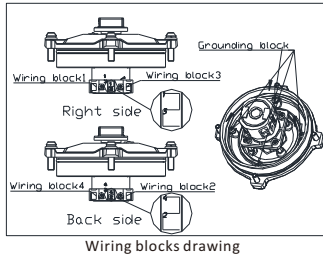

c.Wiring:

	Input wire		Output wire		Remarks
Method 1	L	Block 1	L	Block 2	0:Switch off 1:Switch on
	N	Block 3	N	Block 4	
	GND	Cover inner grounding block	GND	Cover inner grounding block	
Method 2	L	Block 2	L	Block 1	
	N	Block 4	N	Block 3	
	GND	Cover inner grounding block	GND	Cover inner grounding block	

Warning: Block 1&2 and Block 3&4 are the same polarity circuit, otherwise will be short-circuit.

6. 4. 2. 1-2 type

- a.Do wiring and operation according to the switch working circuit.(Picture6.5)
- b.Switch to 1, Circuit 1 (L1,N1) is on, Circuit 2(L2,N2) is off.
- c.Switch to 2, Circuit 2(L2,N2) is on, Circuit 1 (L1,N1) is off

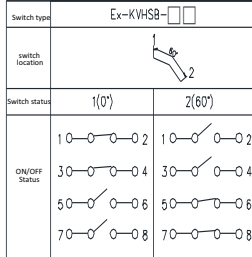

(Picture6.5)

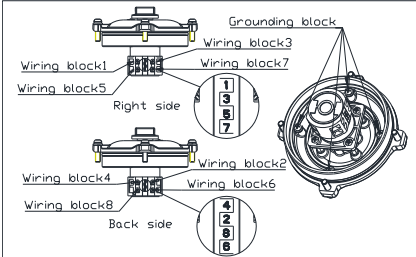

Wiring blocks drawing

d.Wiring:

	Input wire		Output wire		Remarks
Method 1	L	Block 1or5, Connect Block 1&5 with lead wire	L1	Block 2	Circuit 1: L1, N1Controlled by Switch 1
	N	Block 3or7, Connect Block 3&7 with lead wire	N1	Block 4	
	GND	Cover inner grounding block	GND	Cover inner grounding block	
Method 2	L	Block 2or6, Connect Block 2&6 with lead wire	L1	Block 1	Circuit 1: L1, N1Controlled by Switch 1
	L	Block 2&6 with lead wire	L2	Block 5	
	N	Block 4or8, Connect Block 4&8 with lead wire	N1	Block 3	Circuit 2: L2, N2Controlled by Switch 2
	N	Block 4&8 with lead wire	N2	Block 7	
GND	Cover inner grounding block	GND	Cover inner grounding block		

Warning: Block 1&2 and Block 3&4 , 5&6, 7&8 are the same polarity circuit, otherwise will be short-circuit

6. 4. 3. 1-0-2 type

- a.Do wiring and operation according to the switch working circuit.(Picture6.6)
- b.Switch to 0, Circuit 1 (L1,N1) is on, Circuit 2(L2,N2) is off.
- c.Switch to 1, Circuit 1 (L1,N1) is on, Circuit 2(L2,N2) is off.
- d.Switch to 2, Circuit 1 (L1,N1) is off , Circuit 2(L2,N2) is on.

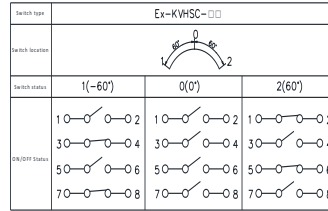

(Picture6.6)

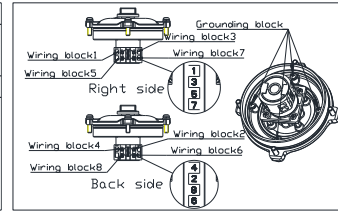

Wiring blocks drawing

d.Wiring:

	Input wire		Output wire		Remarks
Method 1	L	Block 1or3, Connect Block 1&3 with lead wire	L1	Block 4	Circuit 1: L1, N1Controlled by Switch 1
	N	Block 5or7, Connect Block 5&7 with lead wire	N1	Block 8	
	GND	Cover inner grounding block	GND	Cover inner grounding block	
Method 2	L	Block 2or4, Connect Block 2&4 with lead wire	L1	Block 3	Circuit 1: L1, N1Controlled by Switch 1
	L	Block 2&4 with lead wire	L2	Block 1	
	N	Block 6or8, Connect Block 6&8 with lead wire	N1	Block 7	Circuit 2: L2, N2Controlled by Switch 2
	N	Block 6&8 with lead wire	N2	Block 5	
GND	Cover inner grounding block	GND	Cover inner grounding block		

Warning: Block 1&2 and Block 3&4 , 5&6, 7&8 are the same polarity circuit, otherwise will be short-circuit

7.Operation

- 7.1.Do not use junction box which lack of parts.
- 7.2.Do not open when energized.

8.Maintenance

- 8.1.Switch maintenance:
 - 8.1.1.Open the top cover with 4mm hexagon wrench. (Picture 8.1)
 - 8.1.2.Remove the broken switch, and replace with the new switch and connected. (Picture 8.1)
 - 8.1.3.Fasten the cover and cable gland after cable connection. (Picture 8.1)

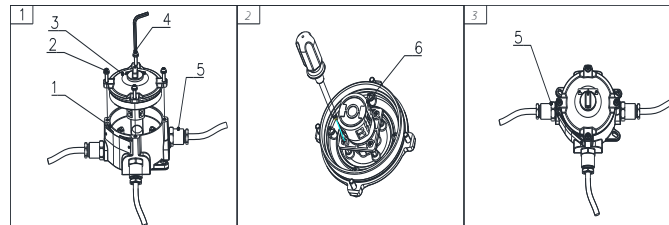

- 1. enclosure
- 2. Allen screw
- 3.top cover
- 4.4mm Hexagon wrench
- 5.cable gland
- 6.Switch

(Picture 8.1)

8.2.Optional Parts:

NO.	Name	Specification	Qty/luminaire	Remarks
1	Switch	0-1	1	
2	Switch	1-2	1	
3	Switch	1-0-2	1	

8.3. Malfunction Diagnosis and Correction:

Malfunction Diagnosis	Analysis	Correction
No working	Abnormal wiring	Check the wiring is right
Tripped	Wrong wiring	Check the wiring is right
Switch can not control the luminaire	Did not wiring	Wiring according to <<3.2 Switch wiring and operation>>
Other problems		Contact service center

8.4.Maintenance:

- 8.4.1.Clean the junction box regularly.
- 8.4.2.Do not clean when energized.
- 8.4.3.Do not clean when working.