

Operation & Maintenance Manual Kingfish Series-NV1.0



CE RoHS

Important information:

These instructions contain safety information, read and follow them carefully. KHJ will not accept any responsibility for injury, damage or loss which may occur due to incorrect installation, operation or maintenance

Product Important Information

Standards	<ul style="list-style-type: none"> • EN 55015, EN 61547, EN 61000-3-2, EN 61000-3-3, • EN 60598-1, EN 60598-2-5, EN 62031, EN 62493, IEC 60529 • IEC 62321-4, IEC 62321-5, IEC 62321-6, IEC 62321-7-1, IEC 62321-7-2, IEC 62321-8
Certificate	CE, RoHS
Ambient Temp	-20°C ≤ Ta ≤ +55°C
Ingress Protection	IP66
Cable Entry	2XM20*1.5/2X M25*1.5

01.Introduction-Kingfish Series LED Linear Light

- This user manual covers the range of industrial KingFish series LED normal luminaire. These luminaires are constructed with corrosion resistant epoxy coated copper free aluminum alloy body and high impact resistance PC diffuser.
- KingFish series LED are available from 18W to 64W, providing ideal solutions for a wide range of industrial applications.

02.Electrical Supplies

size:600*110*103mm			
Voltage Range(AC)	220~240VAC		
Frequency Range(Hz)	50/60Hz		
Power Watts(W)	18W	36W	48W
Standard Current Range(A)	0.07~0.09	0.13~0.18	0.18~0.24

size:1200*110*103mm			
Voltage Range(AC)	220~240VAC		
Frequency Range(Hz)	50/60Hz		
Power Watts(W)	36W	48W	64W
Standard Current Range(A)	0.13~0.18	0.18~0.24	0.24~0.32

Emergency parameters	
Voltage Range (AC)	220~240VAC
Battery	9.6V 2.2Ah, Ni-Cd
Emergency Duration	≥180 minutes
Emergency power	5W
Charge time	>24hours
Power Factor	≥0.89

03.General

- These instructions should be read fully and carefully before attempting to install the luminaire.
For details of servicing operations, opening etc. see section 6.
- Copies of these instructions should be held in a safe place for future reference.
It is the responsibility of the installer to ensure that the apparatus selected is fit for its intended purpose and that the installation, operation and maintenance of the apparatus complies with applicable regulations, standards or codes of practice.
Installation should be carried out by a qualified electrician only.
- Risk of electrostatic discharge:
 - a. Avoid mounting near fast moving streams of air
- Any specific installation instructions must be referred to. The luminaire should be considered Class I to EN 60598 and effectively earthed.
- The information in this leaflet is correct at the time of publication.
The company reserves the right to make specification changes as required without notice.

3.1 Tools

- 4 mm and 5 mm flat blade screwdriver, large cross head screwdriver and inner hexagon counter wrench, suitable spanners for installing cable gland, pliers, knife, wire stripper and cutter.

3.2 Mounting

- Luminaire should be installed where access for maintenance is practical and in accordance with lighting design information.
Refer to the note in 3. concerning electrostatic charge.
- See 6.1 for installation mode and method.

3.3 Cabling and Cable Gland

- When installed the cable gland or sealing plug should maintain the IP rating of the enclosure IP66.
- The thread specification and installation requirements are detailed in the "remarks" part of Clause 6.

3.4 Electrical Connections and Testing

- If any operation is to be done on any luminaire already connected to the electrical system, the luminaire must be isolated from the system.
- To access the mains terminals, loosen the fixing screws, remove the power cover.
- The cable wiring diagram is detailed in 6.2.1. The maximum amount of insulation allowed beyond the throat of the terminal is 4mm².
- The normal method of insulation testing is to connect Live and Neutral together and test between this point.
However, if this is not possible, the luminaire can be tested with an insulation tester that complies with IEC 364 with a maximum output current of 1mA and output voltage of 500V dc (Units damaged by incorrect insulation testing can be detected).
- Before completing the wiring, ensure that all the connections are correctly introduced into place before reassembling the luminaire.

04.Safety Instruction

- Read this leaflet carefully before commencing to install the luminaire unit and retain it for future use.
Installation can only be carried out by suitably qualified personnel.
- Check Product Important Information in this user manual to ascertain type of threaded cable entry on the luminaire.
Select suitable cable glands and stopper plugs.
- The cable entry devices selected must maintain the IP rating of the luminaire.
- The incoming mains cable should not exceed a temperature rise of 20°C above the ambient conditions; select suitable cable.
- External fasteners must have a yield strength of at least 450MPa.
- The luminaire must not be operated without all the individual LED covers in position, the IP66 rating must be maintained.

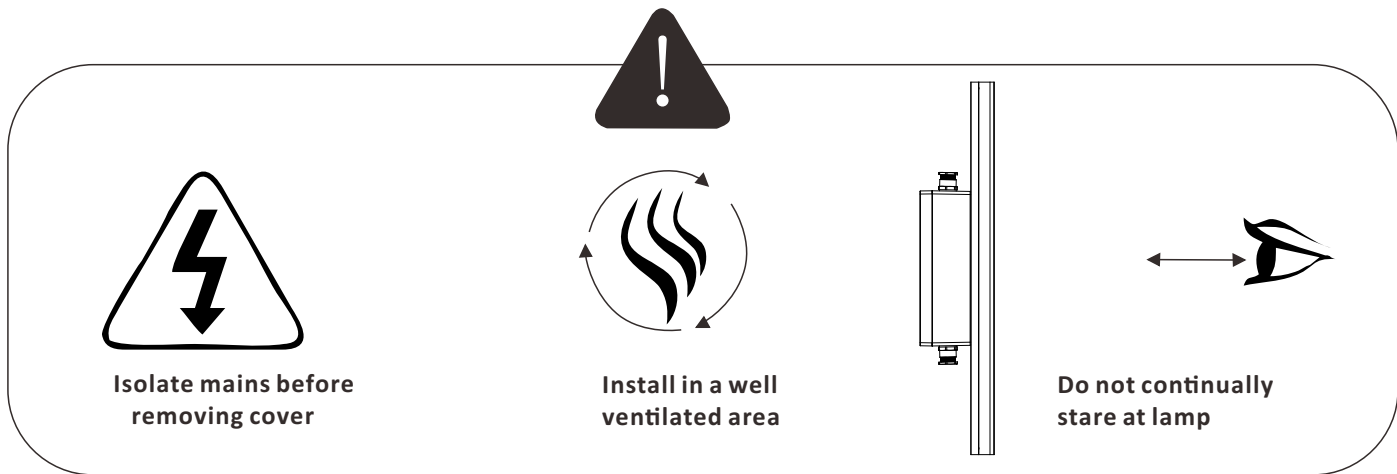

05. Emergency Operation

5.1 General description of operation

- Connect the lead wire of B in the terminal box and then connect to AC power supply to start emergency function.
- Luminaire faults are shown by a flashing red LED.
- Charging is indicated by flashing green LED.
- The luminaire will go seamlessly into emergency mode at not less than 60% rated supply voltage and will remain in mains mode above 85% of rated supply voltage.
- The charging function is monitored continuously, there is a check for over charging and no charging. In case of a control gear error, red LED flashes. Batteries will be fully charged more than 24hrs. After a complete battery discharge, the unit will switch over to a low discharge current mode.

5.2 Emergency indicator status

- The green LED will flash slowly, if the batteries are being charged.
- The green LED will be steady at full charge.
- The red LED will flash quickly if there is a fault or a warning.
- The green LED will be off during emergency mode.
- The red LED and green LED will flash alternately if the battery voltage is less than 8.5V.

06. Installation method

Based on the use of the scene and actual requirements, we have designed the following installation methods for customers to choose from (including but not limited to):

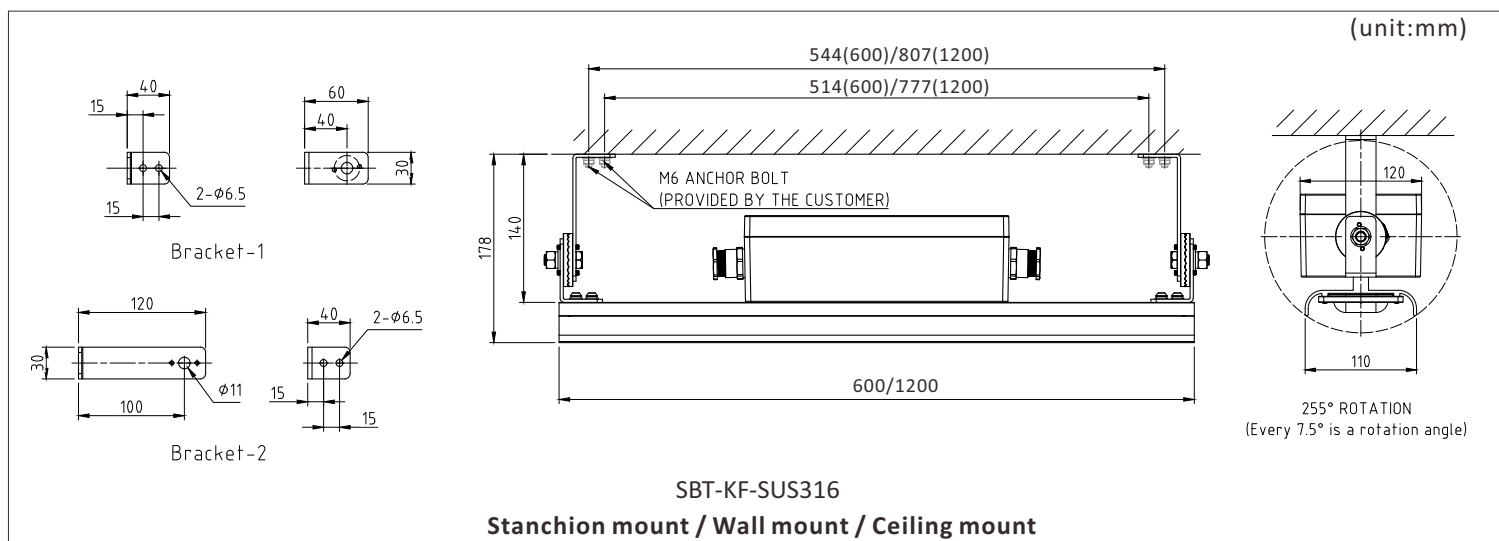

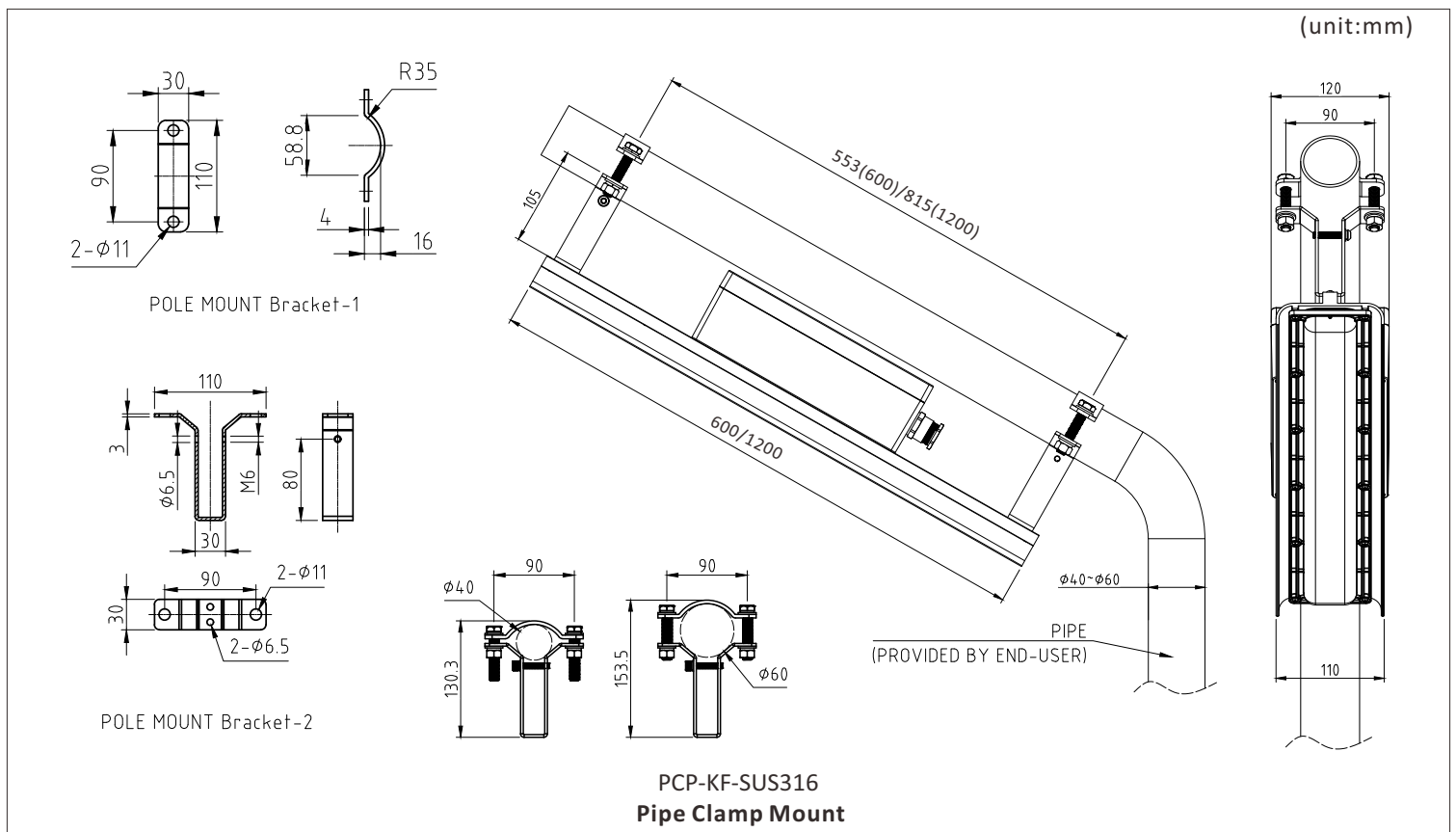
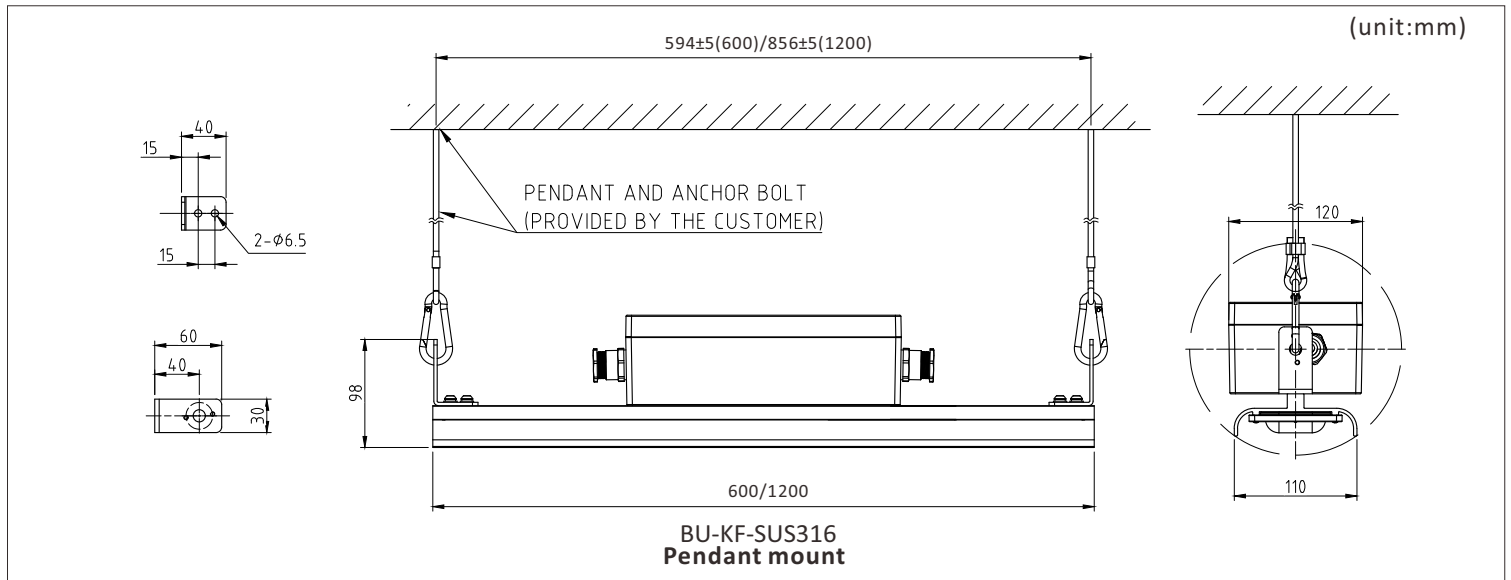

Remarks:

- External grounding cable cross-sectional area is not less than 4mm².
- Entries into enclosures torque of locking cable introduction device 35 N.M~40 N.M.
- Suitable cable glands or plugs
- If using cable gland and stopping plug of KHJ, please refer to below table for cable spec (including but not limited to):

Type	Outer Diameter(mm)
M20 Non-Armoured cable gland	φ8-φ12
M25 Non-Armoured cable gland	φ10-φ14

- If you need to use other cables or different threads in actual installation, please contact the local dealer or our sales specialist.

6.1 Installation decomposition

It is the responsibility of the installer to ensure that the apparatus selected is fit for its intended purpose and that the installation, operation and maintenance of the apparatus complies with applicable regulations, standards or codes of practice. Installation should be carried out in accordance with EN 60598. Please refer to the following installation drawing for different installation methods.

• 6.1.1 Stanchion Mount / Wall Mount/ Ceiling Mount(unit:mm)

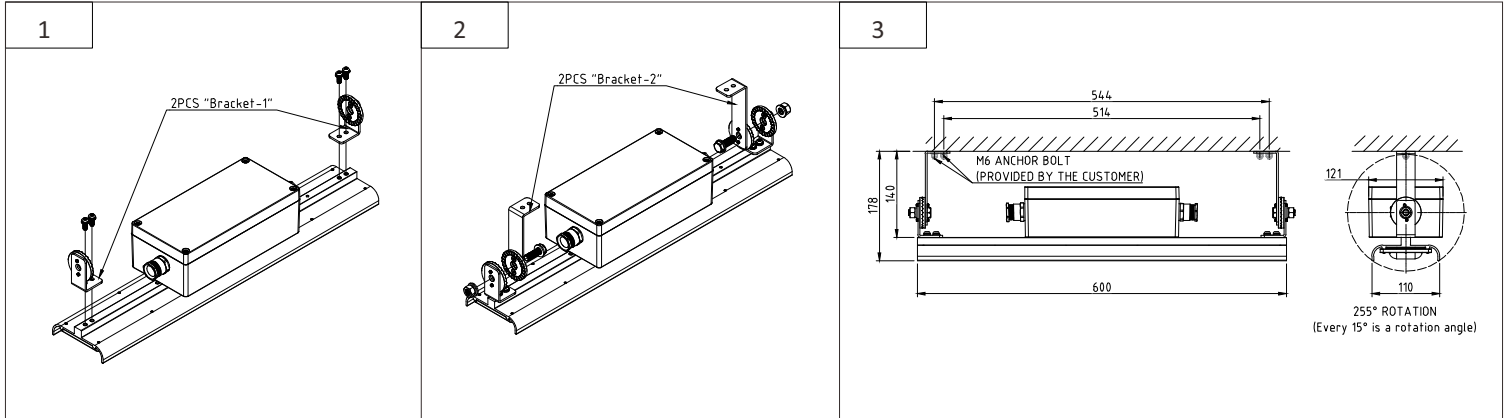

• 6.1.2 Pipe Clamp Mount(unit:mm)

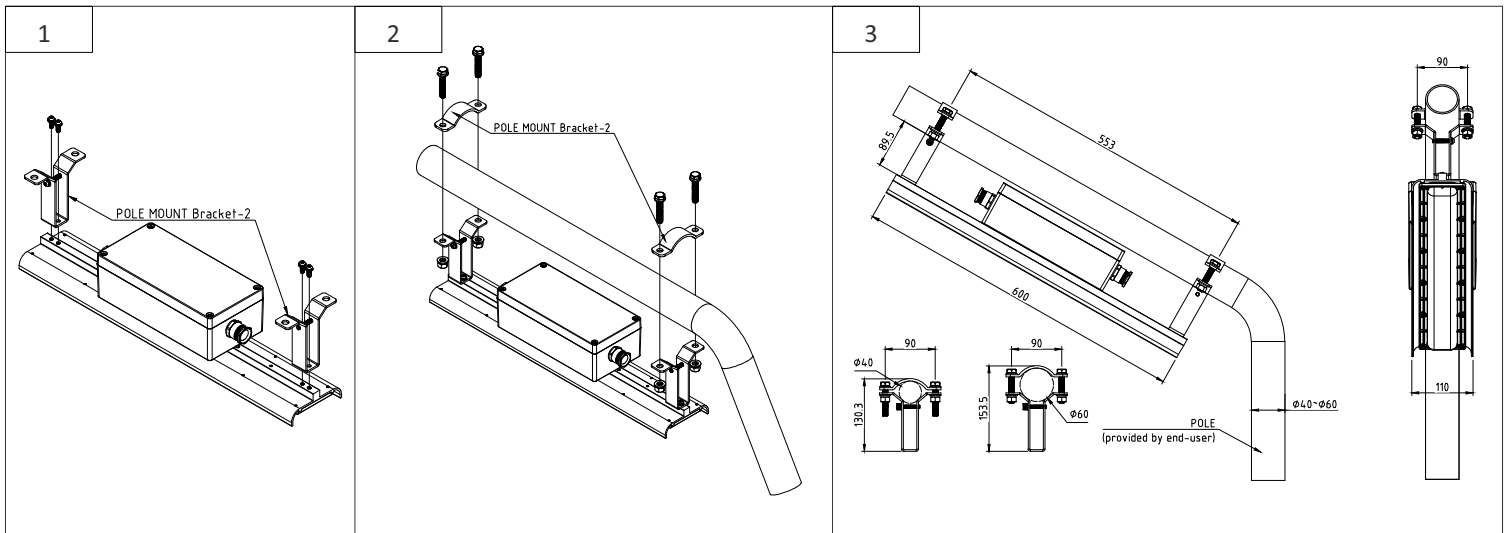

• 6.1.3 Pendant Mount(unit:mm)

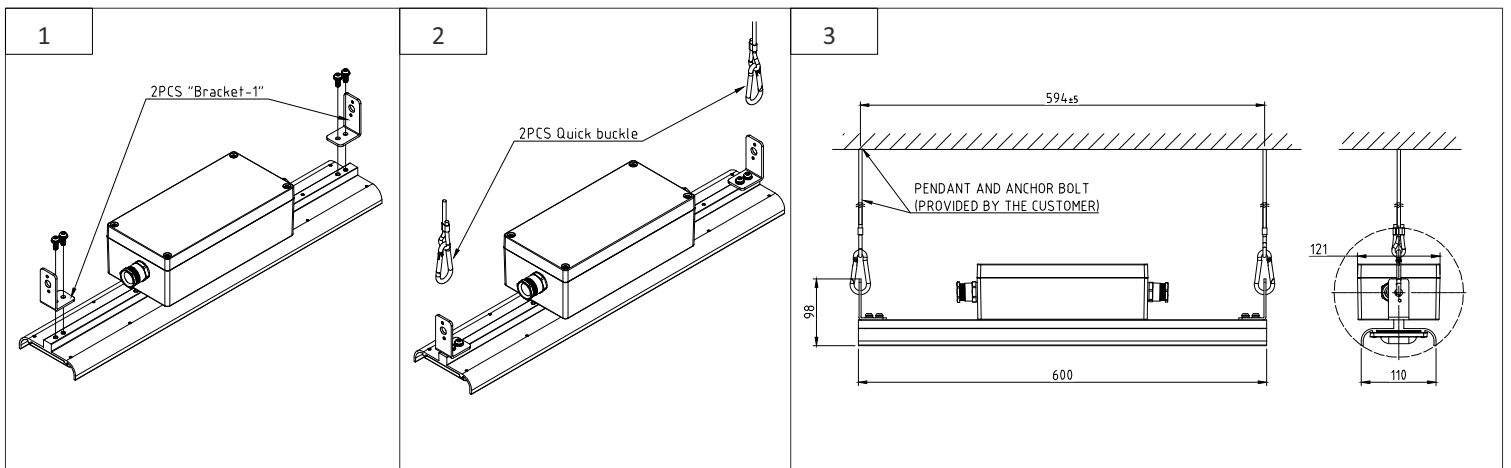

6.2 Electrical Principles and Connections

In addition to referring to the relevant contents of this manual, this product should be installed and maintained by qualified electrician only. When installed, ensure that the luminaire is effectively grounded (internal or external).

6.2.1 Electrical Principles (Emergency ON type)

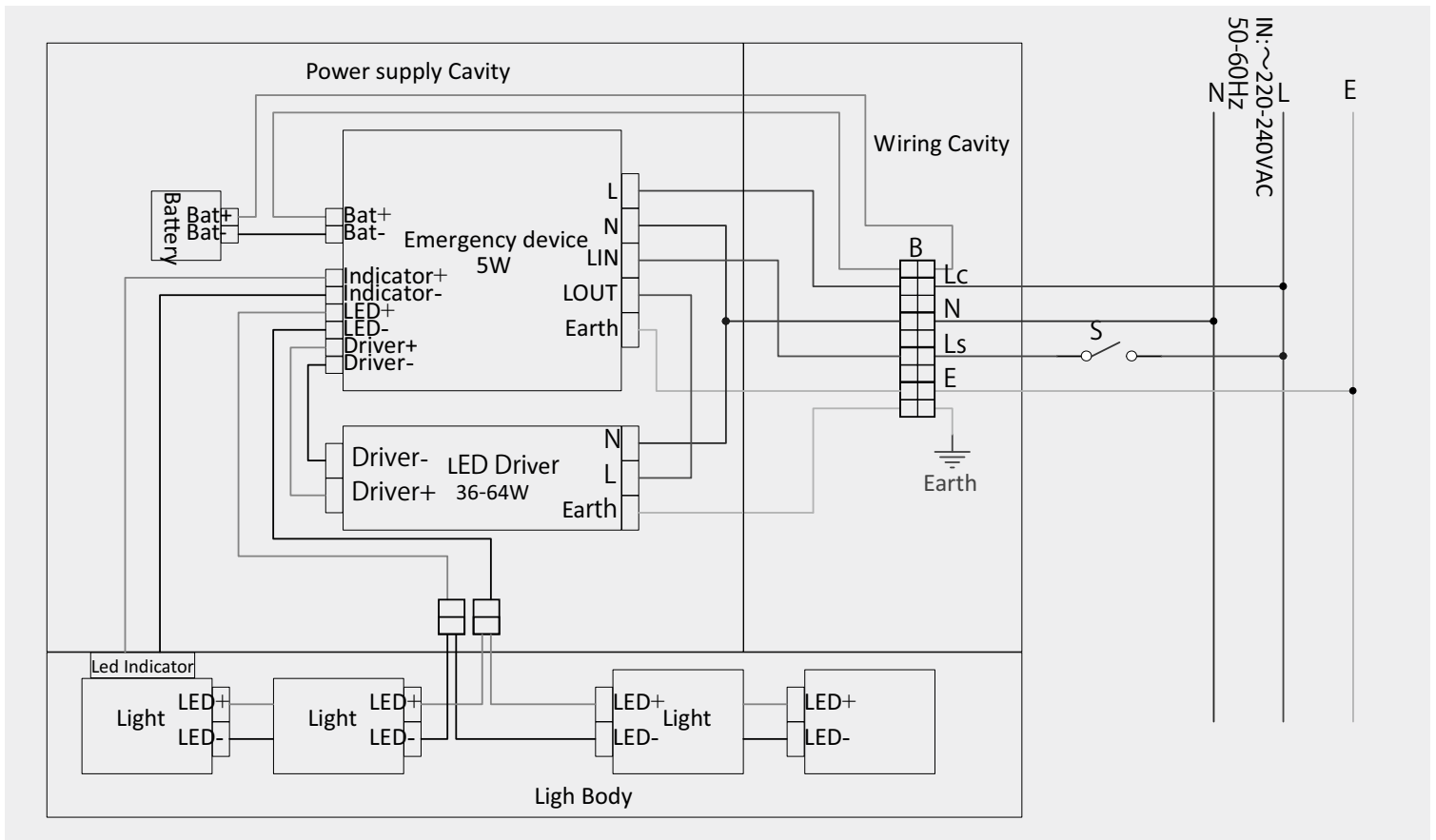
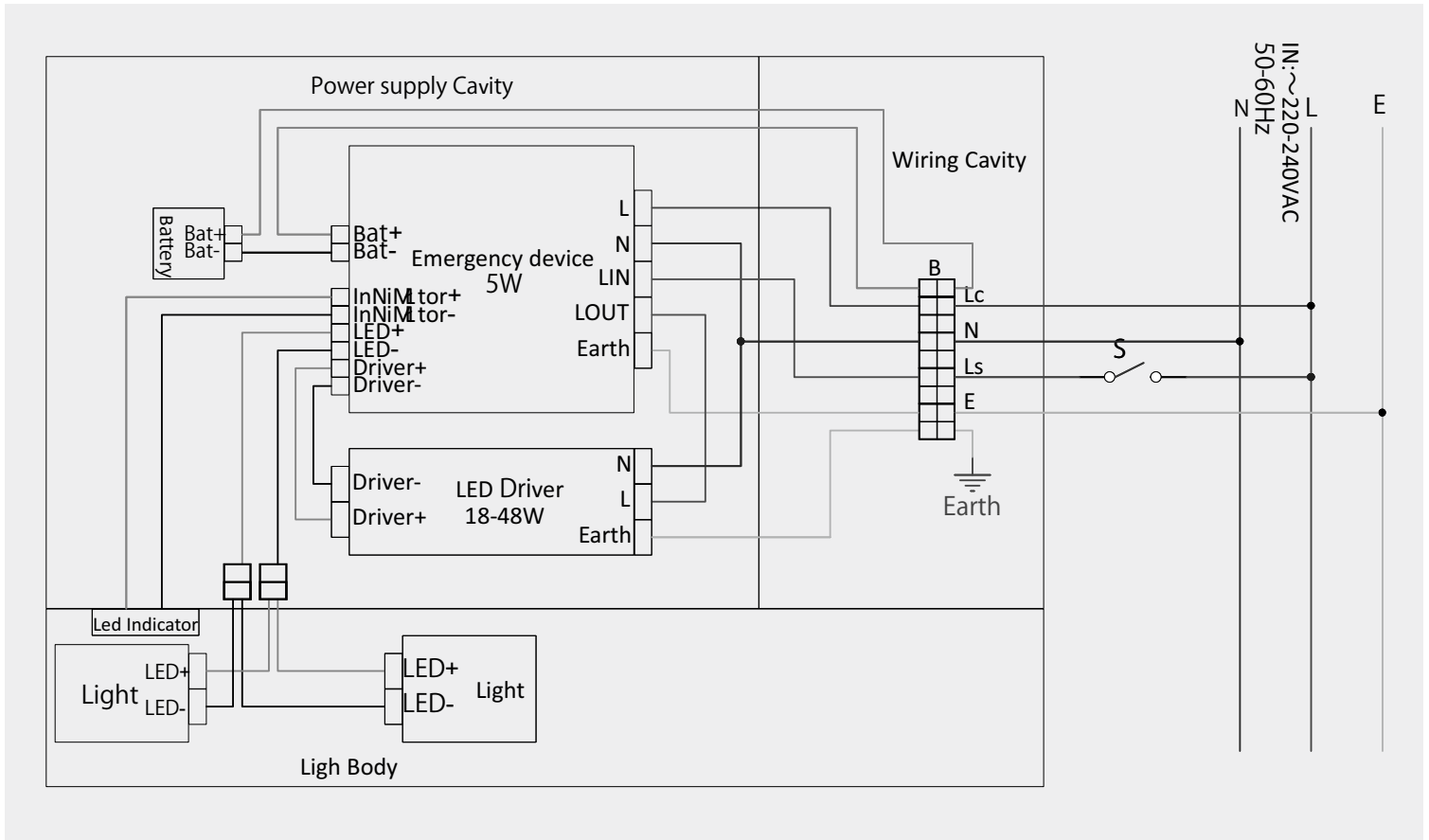

B	Lc, N	S	LED Light
ON	ON	ON	ON
ON	ON	OFF	OFF
ON	OFF	ON\OFF	ON(Back up by battery)

07.Repairs Maintenance

Visual tests and checks should be carried out at intervals described by the appropriate regulations, and should include the following(including but not limited to).

- Check for mechanical damage/corrosion.
- Check connections, fixings, glands and plugs.
- Check for undue accumulations of dust, dirt or moisture.
- Check for unauthorized modifications.

Periodic inspection of the enclosure seal should be checked out to ensure that the seal is sound.

If the luminaire has been subject to abnormal conditions, for example, severe mechanical impact or chemical spillage, it must be de-energised until it has been inspected by an authorized and competent person.

08.Cleaning of Luminaire

- The complete luminaire (without disassemble) can be cleaned with neutral water solution.
After cleaning, rinse with clean water and wipe dry.
- It is forbidden to use any chemical or hydrocarbon solvent cleaner to clean the diffuser, otherwise serious damage may be caused.
- Please clean the luminaire regularly if it is used under dust environment.

09.Disposal of Material

General
Disposal of the luminaire as waste should be carried out in accordance with national regulations.
Any disposal must satisfy the requirements of the WEEE directive [2012/19/EU] and therefore must not be treated as commercial waste.

The unit is mainly made from incombustible materials.
The control gear contains plastic, resin and electronic components.
All electrical components may give off noxious fumes if incinerated.



To comply with the Waste Electrical and Electronic Equipment directive 2012/19/EU the apparatus cannot be classified as commercial waste and as such must be disposed of or recycled in such a manner as to reduce the environmental impact.



10.Transportation

Weatherproof measures should be taken during transportation.
It is strictly forbidden to load and unload violently, and it is strictly forbidden to drop and roll from high altitude, so as to prevent mechanical damage.

11.Storage

The luminaire should be stored in ventilated, non-dropping and non-liquid warehouse at the temperature of -20°C to +40°C and relative humidity ≤95%RH.
The surroundings should be kept from corrosive gases which may damage metal and insulation.

12.Optional Parts

No.	Installation Accessories	Part No.	Picture	Material	Weight(Kg)	QTY	Remarks
1	Stanchion Bracket	SBT-KF-SUS316		SUS316	0.3	2	Ceiling Mount Stanchion Mount Wall Mount
2	Pipe Clamp	PCP-KF-SUS316		SUS316	0.4	2	Pipe Clamp mount
3	Buck Bracket	BU-KF-SUS316		SUS316	0.2	2	Pendant mount



Contact

SHENZHEN KHJ SEMICONDUCTOR LIGHTING CO., LTD.

Web: www.khjled.com

Address: 4-5 Floor, Building 1, Chuangxin industrial park, Xintian community, Guanlan, Longhua new district, Shenzhen, China.

Tel: +86-755-82949977
E-mail: khjledsales@khj.cn

Fax: +86-755-82949800
Web: www.khjled.com